

**RELIABLE PLC AND EASY-TO-USE CONTROLS
PROVIDE DEPENDABLE AND CONSISTENT OPERATION**



START begins operation of the machine at the settings of all other controls.

WRAP/RESET allows the user to select the wrap mode to wrap up only or wrap up and down. Reset brings the carriage and turntable to the home position.

TOP & BOTTOM WRAPS place additional wraps of film at the top or bottom of your load for extra stability.

TURNTABLE AUTO/MANUAL allows automatic or manual jog operation of the turntable.

FILM CARRIAGE MANUAL UP, AUTO, and MANUAL DOWN allows for automatic or manual raising and lowering of the film carriage.

TURNTABLE SPEED adjusts the speed of the turntable for your particular load.

CARRIAGE SPEED allows you to adjust carriage speed for film overlap. The carriage can be stopped for additional “banding” wraps to reinforce the load.

FILM FORCE precisely and consistently controls the film wrapping force applied to the load.

STOP halts all machine functions immediately. Pull stop out and press reset or start button to complete the wrapping cycle.

POWER must be ON to operate your Predator®.

© 2000 Highlight Industries, Inc.

SYSTEM SPECIFICATIONS*

Pre-Stretch Gears.....	200% <small>(Others Available 150%–300%)</small>
Turntable Speed.....	Adjustable to 12 RPM
Wrap Height.....	to 70 Inches
Motors.....	¾ HP 90 VDC
Drive Boards.....	KB Electronics
Load Weight Capacity.....	4,000 Pounds
Electrical.....	115 Volts, 15 Amps
Wrap Modes.....	Two <small>(Spiral Up/Down & Spiral Up Only)</small>
Machine Weight.....	1,260 Pounds <small>*Subject to change without notice.</small>

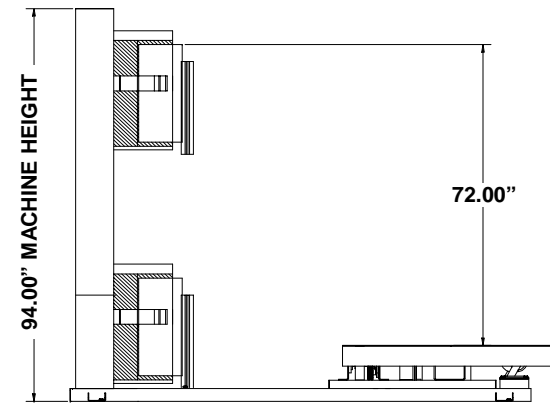
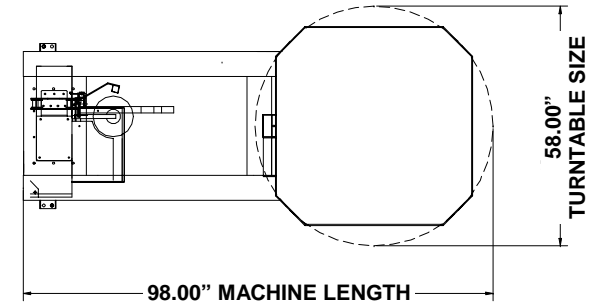

HIGHLIGHT
INDUSTRIES, INC.

2694 Prairie Street SW
Wyoming, MI 49509 • (800) 531-2465
(616) 531-2464 • Fax (616) 531-0506

CONTACT: