

# Highlight Synergy Roll Wrapper

*A stretch wrap machine exclusively designed  
for the unique requirements of the roll products industry!*

The custom-designed Synergy Roll Wrapper will quickly and economically apply stretch film to your roll products, providing protection and total encapsulation. This will allow you to reduce or eliminate your costly current packaging method while providing both a user and environmentally friendly solution.

## Stretch wrap benefits include:

- ☺ Reduction in packaging time and labor cost
- ☺ Product cleanliness and limited weather protection
- ☺ Easy product identification
- ☺ A dramatic decrease in packaging costs!



Highlight manufactures the most complete line of roll wrapping systems in the world in addition to the Synergy turntable model shown. Highlight custom designs Freedom™ spiral overhead, Revolver horizontal, and face roll-wrapping machines. Highlight roll wrapping systems are available for small, medium and large rolls with weight capacities up to 25,000 pounds. Highlight Industries is also a leader in the semiautomatic / automatic pallet wrap and stretch bundling machine industry.

**HIGHLIGHT**  
INDUSTRIES, INC.

2694 Prairie SW • Wyoming, MI 49509  
616-531-2464 • 800-531-2465 • FAX 616-531-0506

[www.highlightindustries.com](http://www.highlightindustries.com)

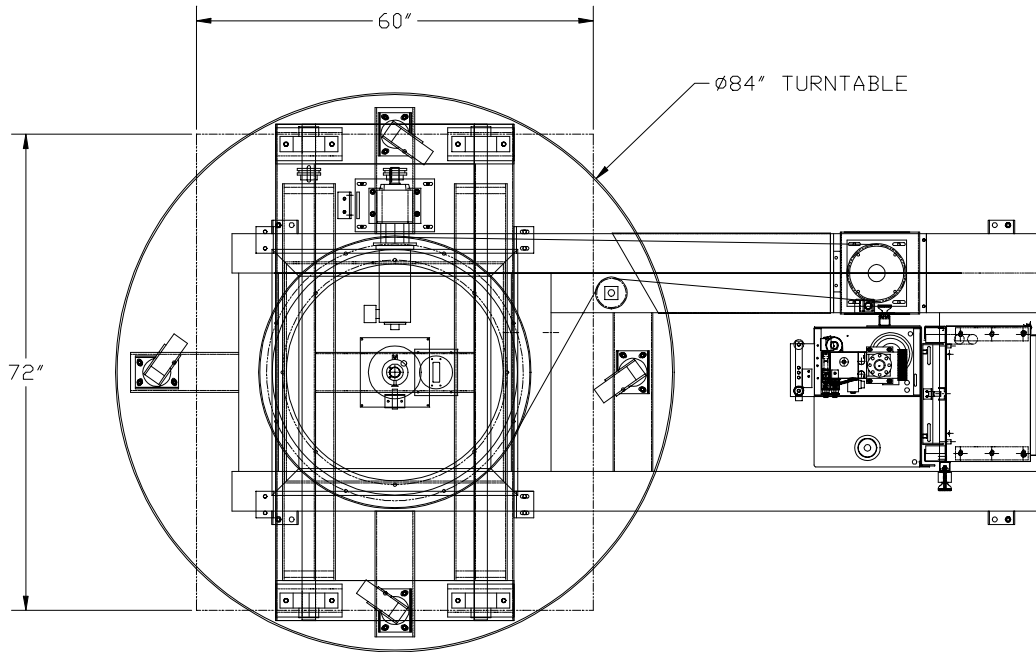

## Model SYNERGY 3RW6072 Roll Wrapper Specifications\*

Max. Roll Size ..... 60" OD x 60" W  
 Roll Capacity ..... 6,000 lbs.  
 Turntable Speed ..... 12 rpm  
 26" Fixed Turning Roller Center

\*Other models and roll sizes available up to 25,000 pounds.

